

TITAN HALF HEIGHT INDUSTRIAL TURNSTILE



- The TITAN Half Height is a medium security, aesthetic choice for your entrance
- Designed for high speed ultra quiet operation
- Exported worldwide

APPLICATIONS

- Suited for applications requiring high volume access and medium levels of security
- Used extensively in applications such as mines, factories, warehouses, universities and stadiums

DESIGNED FOR

- Interior and exterior installations
- Severe operating conditions

AVAILABLE CONFIGURATIONS

- 3 arm (120°) and 4 arm (90°)
- Single and Double

TITAN DIMENSIONS

TITAN SINGLE RANGE			TITAN DOUBLE RANGE		
A	Turnstile width	1 335mm	A	Turnstile width	1 950mm
B	Walkthrough width	525mm	B	Walkthrough width	525mm
C	Overall height	1 195mm	C	Overall height	1 195mm
D	Arm height (1)	860mm	D	Arm height (1)	860mm
E	Arm height (2)	N/A	E	Arm height (2)	935mm

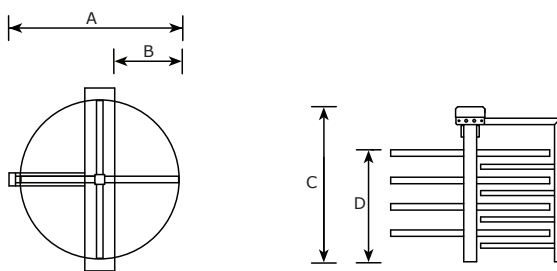
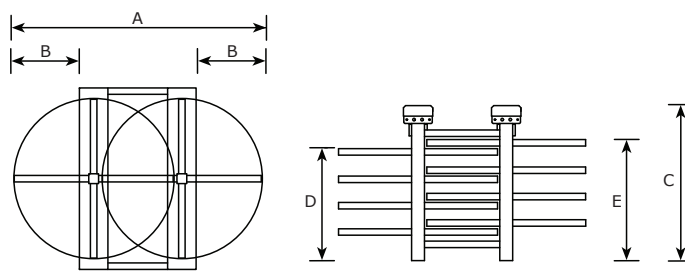
TITAN SINGLE		TITAN DOUBLE	
			

**Note: The turnstile screen shown below is an optional extra.
Due to our policy of continuous improvement, products are subject to change without notice.
Custom designs available on request**

QUALITIES

- 1 Rotalok® rotation locking mechanism and electronic control panel
- Incorporates:
 - Anti-Trap® safety system
 - Suspended Rotor technology
- 2 Lockable top cover
- 3 Mechanical key override
- 4 Shock absorbing rubber coupling
- 5 50mm diameter tube arms
- 6 Access control reader mounting position
- 7 Rotarun® perpetual base bearing
- 8 Wiring entry point
- 9 Optional turnstile screen

